

How do I measure the shaft?

Measuring the shaft

Measuring the large diameter

Measuring the small diameter.

The small diameter can be difficult to measure

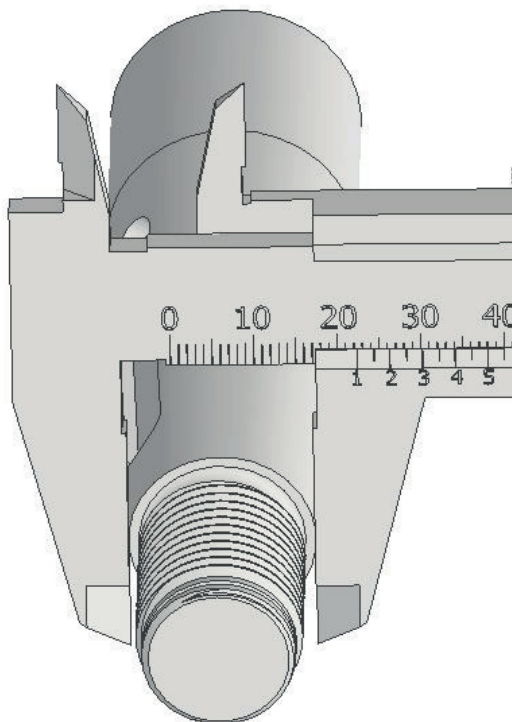
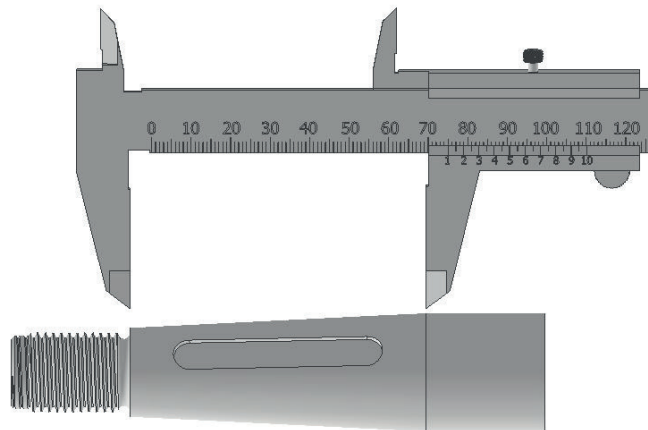
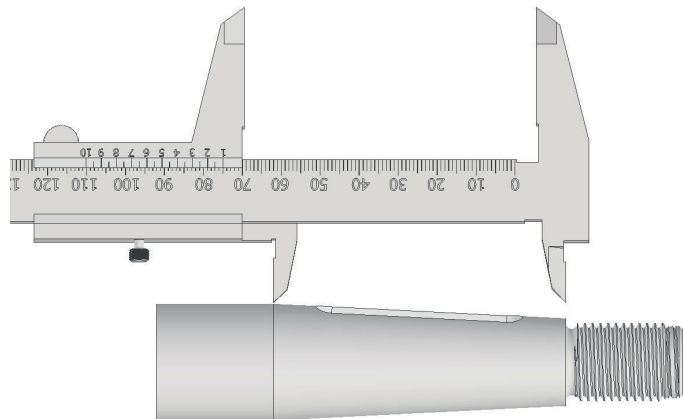
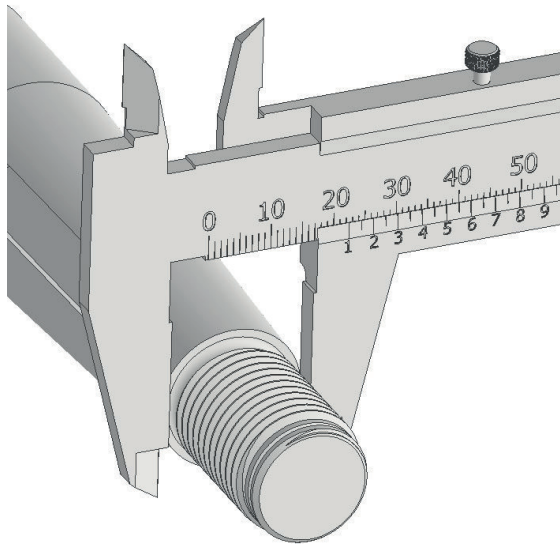

Length of taper

Length of taper must be measured as shown



How do I measure the shaft?

How to calculate the taper (just as an example)

Large diameter = 25mm, small diameter = 19mm, length of taper = 60mm

Length of taper / (Large diameter - small diameter) = taper

60mm / (25mm - 19mm) = 10

Taper = 1:10

Standard tapers are 1:10 (ISO), 1:16 (SAE) and 1:12 (IMP), if it does not fit right on measure a standard taper, it may be the small diameter which is measured incorrectly up or length.

If your taper isn't standard we strongly recommend that you consult a professional who is able to take the correct measurements. This is key to find the right fit.



Thread of the nut

The threads of a nut can be a bit of a task to measure as there are many different threads in inches and metric. Try to measure it as good as you can, then we will help you to find the correct one.

